

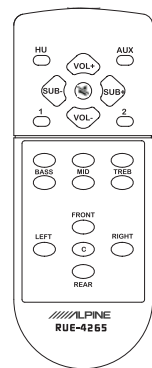

PXE-H650

Audio Processor

OWNER'S MANUAL

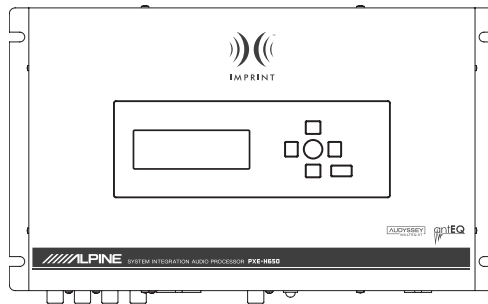



WARNING

It is dangerous and illegal for a driver to watch the Video/TV while driving any vehicle. The driver may be distracted from looking ahead and an accident could occur.

Caution

- Read this manual thoroughly before starting installation and operation. You will find a number of Safety Warnings in this manual to tell you about things that could hurt you or other people if you were to ignore the Warnings. We cannot be responsible for problems resulting from failure to observe the Warnings in this manual.
- This manual uses a symbol to show how to use this product safely and to avoid harm to yourself and others and damage to your property. Here is what this symbol means. Understanding it is important for reading the Manual.
- Meaning of Symbol:



WARNING

This symbol means there is something that could cause serious injury or death to you or other people.

DO NOT DISASSEMBLE OR ALTER

Attempts to disassemble or alter this product can lead to accidental fires or electrical shock.

KEEP SMALL ARTICLES OUT OF THE REACH OF CHILDREN

Keep small articles (wire-ties, etc.) out of reach of children. If swallowed, consult a physician immediately.

USE ONLY IN CARS WITH A 12 VOLT NEGATIVE GROUND

Use only in cars with a 12 volt negative (-) ground electrical system. (Check with your dealer if you are not sure.) Failure to do so may result in fire, etc.

BEFORE WIRING, DISCONNECT THE CABLE FROM THE NEGATIVE BATTERY TERMINAL

Before doing any electrical wiring, disconnect the cable from the negative (-) terminal of the battery. Failure to do so may result in electric shock or injury due to electrical shorts.

KEEP ELECTRICAL CABLES TOGETHER TO AVOID OPERATING HAZARDS

Dress the wiring to keep them from interfering with the operation of the steering wheel, gear lever, brake pedals, etc.

DO NOT CUT AWAY INSULATION FROM ANY WIRE TO POWER OTHER EQUIPMENT

Tapping power from wiring to supply voltage to another piece of equipment could exceed the current carrying capacity of that wire. This could result in fire or electric shock.

DO NOT INSTALL IN LOCATIONS WHICH MIGHT HINDER VEHICLE OPERATION

Do not install in locations which might create hazards for the vehicle occupants or hinder vehicle operation (such as the steering wheel or gear shift) by obstructing forward vision or hampering movement etc.

DO NOT DAMAGE PIPES OR WIRING WHEN DRILLING HOLES

When drilling holes in the chassis for installation, take precautions so as not to contact, damage or obstruct pipes, tanks or electrical wiring. Failure to take such precautions may result in fire.

DO NOT USE NUTS OR BOLTS IN THE BRAKE SYSTEM FOR INSTALLATION OR GROUND CONNECTIONS

Never use safety-related parts such as bolts or nuts in the steering or brake systems or tanks to make wiring installations or ground connections. Using such parts could disable control of the vehicle and cause fire etc.

HALT USE IMMEDIATELY IF A PROBLEM APPEARS

When problems appear, stop using the system immediately and contact the dealer from whom you purchased the equipment. Some problems which may warrant immediate attention include a lack of sound, noxious odors or smoke being emitted from the unit, or foreign objects dropped inside the unit.

DO NOT OPERATE THE EQUIPMENT OR LOOK AT THE SCREEN WHILE DRIVING

Do not change settings while driving. If operation requiring a prolonged view of the display is required, stop the vehicle in a safe location before attempting operation.

HAVE THE WIRING AND INSTALLATION DONE BY EXPERTS

The wiring and installation of this unit requires special technical skill and experience. To ensure safety, always contact the dealer where you purchased this unit to have the work done.

DO NOT INSTALL IN LOCATIONS WITH HIGH MOISTURE OR DUST

Avoid installing the unit in locations with high incidence of moisture or dust. Moisture or dust that penetrates into this unit may cause smoke or fire.

MAKE THE CORRECT CONNECTIONS

Failure to make the correct connections can cause fire or accident to occur.

ARRANGE THE WIRING SO IT IS NOT CRIMPED OR PINCHED

Route the cables and wiring so as not to be crimped by moving parts like seat rails or to make contact with sharp spots which could damage the wiring.

DO NOT RAISE THE VOLUME EXCESSIVELY

Keep the volume at a level where you can still hear outside noises while driving. Driving while unable to hear outside sounds could cause an accident.



PRECAUTIONS

This symbol means important instructions. Failure to heed them can result in injury or material property damage.

Temperature

Be sure the temperature inside the vehicle is between +60°C (+140°F) and –10°C (+14°F) before turning your unit on.

Fuse Replacement

When replacing the fuse(s), the replacement must be of the same amperage as shown on the fuse holder. If the fuse(s) blows more than once, carefully check all electrical connections for shorted circuitry. Also have your vehicle's voltage regulator checked.

Maintenance

If you have problems, do not attempt to repair the unit yourself. Return it to your Alpine dealer or the nearest Alpine Service Station for servicing.

Installation Location

Make sure the PXE-H650 will not be exposed to:

- Direct sun and heat
- High humidity
- Excessive dust
- Excessive vibrations

CONTENTS

Warnings	2
Features/Description	5
SETUP CD - Contents.....	6
CAUTION - Input Level Adjustment.....	6
Remote Control	7
Main Chassis.....	8
Wiring/Connections	9
Basic Operation	
Initial Setup & AntEQ.....	11
MultEQ	13
Demo Mode.....	15
Sound Customization	
Equalizer	16
Crossover	17
Time Delay	19
Mounting.....	20
Adjustments and Ranges	21
Specifications	22

FEATURES/DESCRIPTION

The Alpine PXE-H650 is a versatile processor that takes an OK sounding factory system turns it into a high-end, audiophile system. The PXE-H650 utilizes advanced sound tuning of the factory equipment to correct the acoustical problems inherent in the vehicle. Using AntEQ™ to remove any factory pre-equalization, Audyssey MultEQ™ flattens the frequency response inside the vehicle's interior and adjusts the overall response to a pre-selected target curve.

Once sound levels are balanced, and the system is tuned for optimum response, the addition of Alpine amplifiers and speakers give significant improvement over your factory hardware. Additional amps for tweeters and subwoofers provide a quality, bi-amped system extending the system's response far beyond what a normal factory system is capable of. It's easy to upgrade from factory to Alpine!



WARNING

It is dangerous and illegal for the driver to watch Video/TV while driving any vehicle. The driver may be distracted from looking ahead and an accident could occur.

Features:

- AntEQ and MultEQ (Imprint technology)
- AUX Input (Audio)
- 5-Channel Factory Head Unit Input (Speaker or Line Level)
- 6.1 Channel Analog Line Level Outputs (Front 1/2, Rear, Subwoofer)
- 3 Custom Parametric EQ Bands
- Crossover: Front 1/2 HP, Front 2 LP, Rear HP, Sub LP
- 7-Channel Time Correction
- Source-Tone Memory
- 2 User Presets
- IR Remote Control for Source, Sub Level, Muting, Bal/Fad and User Presets

CAUTION

Input Level Adjustment

The overall sound quality of the PXE-H650 is determined by the adjustments made by the Digital Signal Processor. The accuracy of these adjustments are directly affected by the input to the processor. Therefore, it is very important that the output from the factory radio be properly set so the PXE-H650 receives the correct audio level (not so high that it's distorted and not so low that it's noisy). This ensures that the DSP chip in the unit can see every detail of the audio signal. This important step is done during the initial stages of the Set Up sequence.

The input to the PXE-H650 is equipped with an auto-ranging circuit. This keeps the DSP input at a constant level for better noise immunity and signal processing. It is suggested that the factory head unit volume level be set at about $\frac{2}{3}$ to $\frac{3}{4}$ of its maximum volume. This position should be remembered (mark the control in some way or remember the Volume number in the display) so if it is ever moved, it can be returned easily to the same position. Other functions such as factory EQ settings or position settings must also be turned off. Balance and Fader positions must be centered.

SETUP CD - Contents

H650 Setup Disc

1. Track - Auto range setup
This track is used with auto ranging to set input levels
2. Track - AntEQ setup
This track is used with AntEQ for factory pre-equalization removal
3. Track - Adjust Amp Levels
This track is used by the installer to make coarse adjustments to amplifier levels.

REMOTE CONTROL

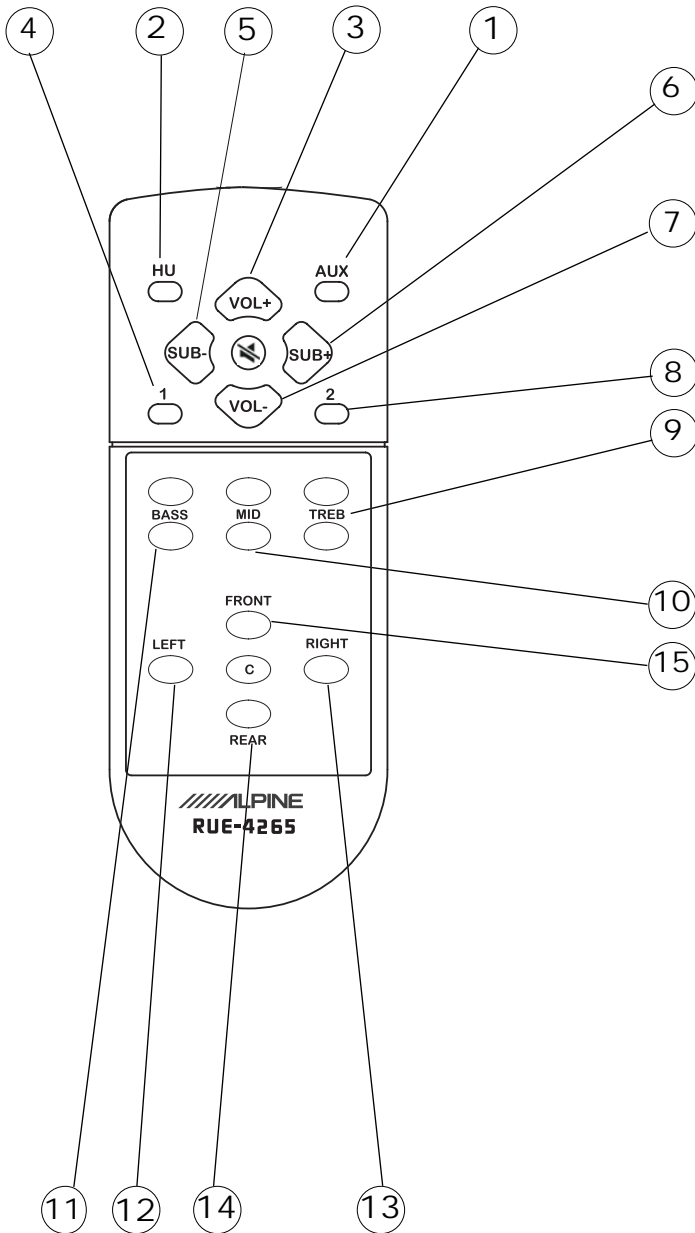

Remote Function Call-outs

- 1 AUX Source Select
- 2 **Factory H/U Select**
- 3 Volume UP
- 4 User Preset 1
- 5 Subwoofer DN
- 6 Subwoofer UP
- 7 Volume DN
- 8 User Preset 2
- 9 Treble EQ UP/DN
- 10 Midrange EQ UP/DN
- 11 Bass EQ UP/DN
- 12 Balance Left (CLEAR)
- 13 Balance Right (DONE)
- 14 Fader Rear (CANCEL)
- 15 Fader Front (MEASURE)
-  Mute
- C Center (both BAL and FAD)

MAIN CHASSIS

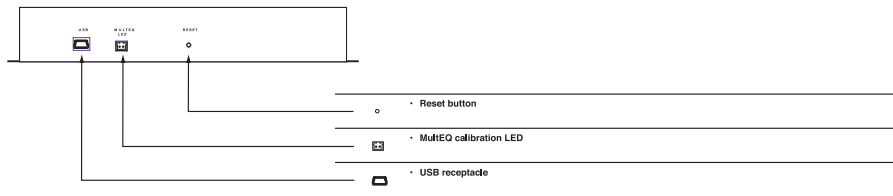
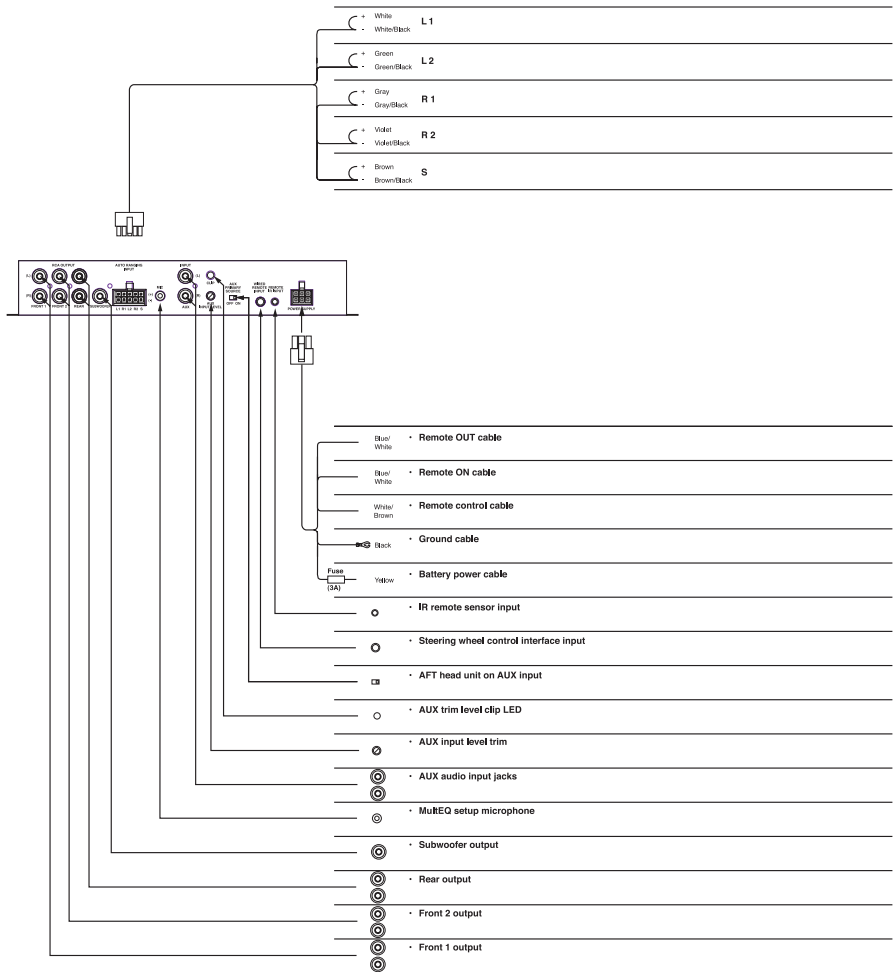

WIRING/CONNECTIONS

Front Panel Chassis

- 1 **USB Port** - USB cable required for PC control/setup (PC software on supplied CD)
- 2 **MULTEQ LED** - Output for included LED; EQ Status indicator during setup
- 3 **RESET** - Press & Release button for: Clear settings, Factory Reset, or Redo MultEQ setup

Rear Panel Chassis

- 4 **POWER SUPPLY Harness (6-Pin)**
 - **Ground (BLK)**
Connect this lead to a good chassis ground on the vehicle. Make sure the connection is made to bare metal and is securely fastened using a sheet metal screw.
 - **Battery (YEL)**
This is a constant +12V for the main unit. It will remain powered even when the Ignition key position is OFF. It draws minimal current to maintain processor memory.
 - **Remote OUT (BLU/WHT)**
This output can turn on external amplifiers. The signal goes high after the PXE-H650 audio mute is OFF.
 - **Remote ON (BLU/WHT)**
If the OEM head unit is not turning on the EQ using the AUTO RANGING INPUT, use this wire. Connect this wire to the 'Auto Turn On' lead of the Factory head unit or a switched 12 VDC source (Ignition).
 - **Remote Control (WHT/BRN)**
This input provides a means by which an external source, connected to AUX, is controlled.
- 5 **REMOTE IR INPUT** (2.5mm mini-phono) - Input for external remote eye (included)
- 6 **WIRED REMOTE INPUT** (3.5mm mini-phono) - Input for steering wheel control (factory option); Note: Using this input disables the factory head unit steering wheel controls.
- 7 **AUX PRIMARY SOURCE** - Turn this switch ON, if a factory radio source is not being used. This accommodates an aftermarket radio using the AUX INPUT.
- 8 **CLIP** - This LED is ON whenever the AUX source is over the input limit.
- 9 **AUX INPUT LEVEL** - Use this trimmer control to adjust the AUX INPUT below clipping.
- 10 **AUX INPUT** - Use this input for an auxiliary source or an aftermarket head with line outputs.
- 11 **MIC** - 3.5mm T/S jack for included microphone
- 12 **AUTO RANGING INPUT** - Use this input for the factory head unit. This input is 'auto ranging' to handle a wide range of factory head unit outputs. It will accept speaker or line level outputs. It has 5 input pairs for Front & Rear Left +/-, Right +/-, and Subwoofer +/-.
- 13 **RCA OUTPUT** - 2 Front L/R Pairs, 1 Rear L/R Pair, 1 Subwoofer Mono
 - Front L1/R1 For Factory High-pass Output
 - Front L2/R2 For Factory Low-pass Output (or Full Range Output)
 - Rear L/R For Factory Rear, Full Range Output
 - Subwoofer For Factory Subwoofer Output

Note: OUTPUT: For full-range only, use outputs FRONT L2/R2
INPUT: If there is a L/R pair of full range outputs available from the factory system (FRONT or REAR) these should be used first and connected to inputs L2/R2 on the H650. If the factory 2-way output must be used, connect Tweeter Left to L1, Woofer Left to L2, Tweeter Right to R1, and Woofer Right to R2.

PRIOR TO SETUP

Before Running AntEQ

The following guidelines will ensure a smooth and accurate setup procedure. Have the MultEQ CD, microphone and LED available and take a note of the conditions below as they are needed in the next section. Some type of stand is also needed to place the microphone at different locations in the vehicle. A clip or tape is not always a good idea as not everyone's ear can be stuck to the headliner or clipped to the visor. The best locations are where a head is most likely to be found (along with its accompanying body).

1. Determine the factory system's output type (full-range or two-way). If you know that your vehicle has tweeters mounted in the dash or door panels, the Factory Radio probably has two-way outputs.
In the case of a two-way system, make sure the tweeter output goes to the L1/R1 inputs and the low output goes to the L2/R2 inputs. At this time, decide the crossover point for the high-pass speakers. Find the low cut-off point of the tweeters and use that as the HP cut-off (5 kHz by default). The mid-bass low-pass cut-off is determined by tweeter high-pass. If there is a subwoofer in the system, the low pass cut-off will be set automatically by MultEQ.
If the output is full range, the factory radio output must go to the L2/R2 inputs.
2. It is recommended to start MultEQ calibration with the 1st MIC position in the driver's seat and the 2nd MIC position in either the passenger's seat or in between the two front seats. Just remember, the more positions that are included in the calibration, the better the results will sound. MultEQ requires a minimum of 4 MIC positions and has a limit of 8. The number and location of the MIC positions is left up to the user. However, following the guidelines described here have been found to give the best results.
3. PRESET 1 settings are derived from MIC position 1 and PRESET 2 settings are derived from MIC position 2. The 3rd through 6th MIC positions should be grouped where the driver's head would be positioned. The 7th and 8th MIC positions should be in the rear seats.

NOTES:

- It is possible that poor MIC positioning could cause anomalies in the calculated response curve. If this happens during the first calibration run, try moving the MIC positions 3 through 8 to more favorable positions.
- If using the AUX Input as the primary source for the EQ, the REMOTE ON wire must be used. Otherwise, there is no way for the EQ to turn on. Use the Remote On wire from the head unit or a source of switched ACC voltage (Ignition).

BASIC OPERATION

Initial Setup & AntEQ

Initially, a blank display is shown during sleep mode (before head unit powers up).

1. TURN ON Vehicle Ignition Switch
2. TURN ON Factory Radio Power and insert the H650 Setup CD.
If properly connected, the Factory Radio Power should automatically turn ON the PXE-H650. The PXE-H650 display = "ALPINE PXE-H650" if already setup.

If this is the very first time the PXE-H650 is being used, the system will enter the SETUP mode automatically. When it does so, follow the steps below. If you don't enter the setup mode automatically please refer to page 15 and FACTORY RESET.

3. Adjust Factory Head Unit.
Head unit controls such as TONE, EQ or other special processing must be turned OFF. Set BALANCE and FADER controls to their center position. Make sure that the volume control on the factory head unit is set at about $\frac{2}{3}$ to $\frac{3}{4}$ of its maximum output. This will ensure that any automatic frequency compensation circuitry in the head unit is off. It also ensures that the output is not distorted but at a high enough level to provide a good signal for accurate processing to take place.

The PXE-H650 utilizes an auto-ranging circuit for the Factory Head Unit input. This enables considerable flexibility in making output adjustments of the factory head unit.

Once the level is set, the factory volume control (and others) should not be changed. Volume will be controlled through the PXE-H650 using the supplied remote control.

Play Track 1, "Autorange Setup," of the Setup CD loaded in Step 2 above.

4. "ENTER TO SETUP"
This is displayed when the PXE-H650 is Powered UP for the first time (or after a 'FACTORY RESET' is performed). Press "ENTER" to initiate SETUP sequence. SETUP continues with Auto Ranging level setting ("CHECKING INPUTS").
5. "CHECKING INPUTS" - Checking and setting input levels from the head unit
Before AntEQ begins analyzing the factory radio's output, proper signal levels are required. The Auto-ranging process is completed when "ENTER TO START ANTEQ" is displayed.

Play Track 2, "AntEQ Setup", of the Setup CD loaded in Step 2 above.

6. "ENTER TO START ANTEQ" - Continue with AntEQ processing
Press ENTER to continue to the AntEQ procedure. Whatever levels were set during auto-ranging are now used as the baseline response for AntEQ.

BASIC OPERATION

7. "AntEQ SAVING" - AntEQ completes and saves the resulting filters. AntEQ has flattened out any equalization that is inherent in the factory radio. This is in preparation for the MultEQ process in the upcoming steps. After completing this process, the settings are saved and recalled when required for new settings.

2-Way Output Settings

8. "2-WAY OUTPUT" - Following "AntEQ SAVING"
If the FRONT Output is configured as a 2-Way system, select 'Y' at the prompt and press "ENTER." The default 'N' assumes only a single, full range Front (Front L2/R2). If 'Y' is selected, the crossover is set in Step 9 below.

If 'N' is selected, skip to the AMP LEVELS adjustments. FRONT 1 is turned OFF and FRONT 2 is set as a Full Bandwidth output.

WARNING: Output of the PXE-H650 is not muted at this point. Make sure volume levels are at reasonable levels.

9. "FRONT 1 HPF" - Set the High-pass crossover point
The FRONT 1 high-pass crossover is set to 5 kHz by default. This also selects the FRONT 2 Low-pass crossover at the same point.
Use the ▼ or ▲ button to change the value in the HPF field. Values available for each crossover are listed in the "ADJUSTMENTS & RANGES" section.
Press "ENTER" to continue.

WARNING: Output of the PXE-H650 is not muted at this point. Make sure volume levels are at reasonable levels.

Amplifier Levels

10. "ADJUST XOVER + AMP LEVELS" - Make adjustments to match amp levels
Play Track 3 of the PXE-H650 Setup Disc in the Factory Head unit. This is a Pink Noise signal to facilitate the trimming of the amplifier level controls.

WARNING: Output of the PXE-H650 is not muted at this point. Make sure volume levels are at reasonable levels.

While listening to the system, use the amp's level controls to match the output of each of the speakers. Level matching does not have to be exact as the MultEQ processing will make the final tweaks to the system. Matching levels as closely as possible makes MultEQ's job a little easier and faster. Typical coarse amp levels are:

12 o'clock (middle position on gain controls) for Front and Rear amp input levels,
9 o'clock (or 1/4 position) for Subwoofer amp input level.

11. After all adjustments have been made, press "ENTER" to continue to MultEQ calibration.

BASIC OPERATION

MultEQ Calibration

At this point in the process, a baseline response curve has been created and stored for your specific vehicle. This curve ensures that the MultEQ algorithms are working with a reasonably neutral sounding curve. This eliminates all the peaks and dips in the source unit, making MultEQs job much easier.

1. "ENTER TO START MULTEQ" - Prepare vehicle for calibration
Make sure the MultEQ LED and microphone are connected (TIP: LED is OFF if no mic connected). The MultEQ LED is Green and blinks at 1Hz when LED and Microphone are properly connected.

The microphone should be placed in the primary listening position (normally the driver's seat). This position is saved as PRESET 1 and is used as the reference for all further DSP calculations. Plan to use at least 6 different positions for optimum performance (minimum is 4 and maximum is 8 positions)

Press "ENTER" to start the MultEQ calibration procedure. The MultEQ LED blinks slowly (1 Hz) during normal operation.

2. "CONNECT LED & MIC"
If the PXE-H650 does not detect the microphone, "CONNECT LED & MIC" is displayed and the MultEQ LED blinks quickly. Troubleshoot the microphone to ensure proper operation and connection. The system will continue automatically when the microphone is detected.
3. "MEASURE POS 1" - Prepare to run the calibration test
If the Mic checks out in Step 2 above, the MultEQ LED is blinking slowly.

Position the Mic in location 1 and exit the vehicle. Close all windows.

Press MEASURE on the remote control to begin (see Page 7).

4. "CHK OUTPUTS & MIC" - Speaker detection Error
If there was a problem during the Speaker Detection process, the PXE-H650 displays the above error display on the LCD and the LED will blink quickly. Troubleshoot the system by making sure that nothing has become disconnected or turned off.

Press the reset button after correcting any problems. Navigate to "RECALIBRATE MULTEQ" in the display. Press "DONE" on the remote control to finalize MultEQ filter calibration or "MEASURE" to the next mic position of calibration. The LED blinks slowly between position measurements.

BASIC OPERATION

5. "MEASURE POS 2"
Reposition the microphone to the secondary position in the vehicle. When ready, exit the vehicle and press "MEASURE" on the remote control to begin. The MultEQ LED illuminates a steady green.
6. "CHK OUTPUTS & MIC"
If the MultEQ LED is blinking fast, something may have happened to the mic during the user's exit. Make any necessary corrections to position, etc. It will then be necessary to restart the calibration sequence. At this point, press the reset button and navigate to the "RECALIBRATE MULTEQ" option screen. Press "ENTER" to select this option. The "2-WAY OUTPUT" screen is displayed. Configure this setting the same as previous MultEQ sequence. Press "ENTER" and re-check amp and crossover levels with Track 3 -Pink Noise. Press "ENTER" when ready to restart the MultEQ calibration sequence. Resume the first MIC position measurement (and speaker detection) by jumping back to step 3 when ready.
7. Next MIC Position
At the "MEASURE POS 3" display, reposition the microphone to another position. Repeat Step 5 above for this new position.

Continue this process for up to 5 more microphone positions. 4 calibrated positions is the minimum for proper MultEQ response. 6 positions is recommended for optimal results. Normally, the more locations used, the more accurate the final EQ curve.

NOTE:

Mic Position 1 is stored in PRESET 1. Mic Position 2 is stored in PRESET 2. Equalization and Time Delay will be optimized for these two positions.

8. Done
After completing the desired number of MIC positions, press "DONE" while "MEASURE POS X" (Where X is either 5,6,or 7) is showing on the display. When calibration is completed in the last step, "CALCULATING FILTERS" then "SAVING FILTERS" is displayed on the LCD and finally "ALPINE PXE-H650" is displayed.

BASIC OPERATION

NOTE:

Press the "RESET" button on the main chassis, any time during the calibration process, to return to the Main Menu. From the Main Menu, four options are available.

- **RECALIBRATE MULTEQ:** Press ENTER at this display to clear the previous MultEQ settings. The current levels and AntEQ settings are not changed.
- **CLEAR SETTINGS:** Press ENTER at this display to clear all Customization settings. This returns the processor to the last MultEQ baseline response.
- **FACTORY RESET:** Press ENTER at this display to return the PXE-H650 to its original factory condition. The entire calibration procedure must be redone.
- **CANCEL:** Press ENTER at this display to return to PXE-H650 STANDBY mode.

Demo Mode Overview

- Demo mode will allow the user to audition MultEQ/AntEQ ON and OFF with the press of a single button on the remote control.

Demo Mode

- Press the MODE button once on the PXE-H650 to reach the Demo mode screen on the LCD. Press the "ENTER" button once to enter the Demo mode. At this time, "DEMO MODE ON" appears in the display. Press the Fader "REAR" button to turn OFF MultEQ/AntEQ, while pressing the Fader "FRONT" button turns MultEQ/AntEQ ON.
- While in the Demo mode, all remote controller buttons are locked out except: Volume UP, Volume DOWN, HU and AUX source switch buttons, and MUTE (if AUX PRIMARY SOURCE switch is ON then HU source switch button is also locked out).
- Press the "ENTER" button again to turn off the Demo mode and resume normal operation. At this time, "DEMO MODE OFF" appears in the display.

SOUND CUSTOMIZATION

Introduction

Each output of the PXE-H650 has a 3-Band, parametric equalizer, up to 10 ms of time correction and customizable crossover points for High-pass, Low-pass and Subwoofer. Experimentation with the sound is encouraged, as a simple press of the RESET button and selecting "CLEAR SETTINGS" will return all settings back to their original, corrected levels before customization began.

The following procedure explains the steps necessary to customize the Parametric EQ, Time Delay and Crossover. Use the same procedure described below, for each of the channels being modified. Pressing "ENTER" gets you into the program screen mode, which will allow current values to then be changed. **Navigate to "SAVE SETTINGS" screen and press ENTER to store changes in memory.**

Parametric Equalizer

The Equalizer uses 3 Bands for each of the 7 channels to customize the tone of the music. Each Source Input to the PXE-H650 has its own EQ. Each of the Bands (Bass, Mid and Treble) is adjusted in a similar manner. The following steps use the Bass Band as an example. Use the same steps to make changes to the Mid and Treble Bands as well.

Equalizer

1. Press MODE to enter Custom Tuning mode.
2. With "PRESET 1" in the display, use the ▼ or ▲ buttons to choose the MIC position to modify or to choose the EQ Adjustment mode. (PRESET 1 or PRESET 2)
 - a) PRESET 1 refers to the Primary Mic position. PRESET 2 refers to the Second mic position.
 - b) Upon making the Mic Position selection, use the ► button to move to the next selection mode. The next parameter to modify (Crossover, or Time Delay) is selected as described following EQ Adjustment.
 - * Use the ◀ button to return to the PRESET selection mode.
3. EQ Adjustment
 - a) Use the ▼ or ▲ buttons to select "CUSTOM AUX EQ" or "CUSTOM HU EQ."
 - b) The user can also use these buttons to select "CROSSOVER" or "TIME DELAY" when in the PRESET 1 or PRESET 2 menus (in 2b above).

The following BASS adjustment procedures are similar in nature to the MID and TREBLE adjustments. Substitute "MID" or "TREB" for "BASS" and perform the same procedure mentioned below for "BASS."

SOUND CUSTOMIZATION

4. Select the EQ Band to adjust.
 - a) Use the ▼ or ▲ button to make the selection. In this example, "BASS" (or "MID" or "TREB").
 - b) Once the Band has been selected, Press "ENTER" to begin making the adjustments.
5. Modify 3 different EQ parameters: LEVEL, Q, and Fc. Use the ► or ◀ buttons to choose the parameter to modify. Use the ▼ or ▲ buttons to change the parameter.
 - a) **LEVEL** is adjustable from -6 dB to +6 dB using the ▼ or ▲ buttons.

This adjustment will effectively lower by 25% or increase by 400%, the output at the center frequency. The LEVEL changes in 1 dB steps.
 - b) **Q (Q-factor)** is adjustable from 0.5 (wide band) to 2.0 (narrow band).

The Q determines how much the frequencies below and above the center frequency are affected by the LEVEL adjustment in 'a.' Use the ▼ or ▲ buttons to choose a Q-factor from 0.5 to 2.0 in steps of 0.5.
 - c) **Fc (center Frequency)** is adjustable from 30 to 150 Hz.

This is the point of maximum effect for the EQ LEVEL adjustment. All frequencies above and below Fc are affected to a lesser degree, depending on the Q setting. The frequencies are selectable using the ▼ or ▲ buttons. They vary for each band and are listed below.

BASS EQ: Fc = 30, 40, 50 60, 80, 100, 125, 150 (Hz)
MID EQ: Fc = 500, 750, 1k, 1.5k, 2k, 3k, 4k, 5k (Hz)
TREB EQ: Fc = 6k, 7.5k, 10k, 12.5k, 15k, 17.5k (Hz)
 - d) Upon completing the adjustment, press ENTER to save values and exit back to the "CUSTOM EQ" HU or AUX sub-menu headings of BASS, MID or TREB EQ.
 - e) Use the MODE button at any point, to return to the previous sub-menu.

Crossover Overview

The PXE-H650 crossover allows custom cut-off points for the high-pass and low-pass filters of the Front and Rear speakers and the Subwoofer. This is especially useful when the factory speakers have been upgraded to handle a much wider audio bandwidth.

Crossover

1. Press MODE twice to enter Custom Tuning mode.
2. Navigate to the right with the right cursor button. With "PRESET 1" in the display, use the ▼ or ▲ buttons to choose the MIC position to modify.
 - a) PRESET 1 refers to the Primary Mic position. PRESET 2 refers to the Secondary position.
 - b) Upon making the Mic Position selection, use the ► button to move to the next selection mode. The next parameter to modify (Crossover, or Time Delay) is selected as described below.

* Use the ◀ button to return to the PRESET selection mode.

3. Crossover Adjustment

- a) Use the ▼ or ▲ button to make the selection. In this example, "CROSSOVER"
- b) The user can also use these buttons to select "TIME DELAY."

The following "FRONT 2" adjustment procedures will be similar in nature to adjustments for the other channels. Just substitute "FRONT 1," "REAR," or "SUBWOOFER," for "FRONT 2." The procedure is the same with only the parameters slightly different, as shown at the end of this section.

4. Enter the Channel select mode by using the ► button. "FRONT 1" is displayed.
 - a) Use the ▼ or ▲ button to choose a channel. In this example, "FRONT 2." Note: Use the same procedure to select any of the other channels.
 - b) User can also use the ◀ button to return to the previous level with "CROSSOVER" or "TIME DELAY" selections.
 - c) Once the channel has been selected, Press "ENTER" to begin making the adjustment.

5. Modify 2 different Crossover parameters: LEVEL and Fc (cut-off Frequency). Once Fc is selected, the Crossover becomes active. Use the ► or ◀ buttons to choose the parameter to modify. Use the ▼ or ▲ buttons to change the parameter.
 - a) LEVEL is adjustable from -15 dB to +15 dB using the ▼ or ▲ buttons. This adjustment changes the LEVEL in 1 dB steps. The range for this parameter remains the same for ALL Channels in ALL modes.
 - b) The Fc adjustment depends on the output mode. The ▼ or ▲ buttons select the frequency. The frequency range of FRONT 2 changes based on the FRONT 1 configuration. Once FRONT 1 is activated (Fc selected), FRONT 2 changes from a High-pass crossover to a Band-pass crossover. This is to accommodate the 2-way output mode. The Fc changes as follows:

Output Mode	FRONT 1	FRONT 2	REAR	SUB
2 or 4 CH, w/wo Sub	NA	HPF: 50 - 200 Hz @ -12 dB/oct	HPF: 50 - 200 Hz @ -12 dB/oct	LPF: 50 - 200 Hz; -12/-24 dB/oct
2-Way, 4-CH, 6-CH; w/wo Sub	HPF: 200 - 5 kHz @ -12 dB/oct	LPF: 200 - 5k Hz @ -12 dB/oct; HPF: 50 - 200 Hz @ -12 dB/oct	HPF: 50 - 200 Hz @ -12 dB/oct	LPF: 50 - 200 Hz; -12/-24 dB/oct

- c) For the Subwoofer Channel, a third parameter is available. Use the the ▼ or ▲ buttons to toggle between the 12 dB/oct or 24 dB/oct crossover slopes.
- d) Upon completing the adjustment, press ENTER to exit back to the "CROSSOVER" sub-menu.
- e) If all CROSSOVER adjustments have been completed, use the ◀ button to return to the PRESET selection mode. Press ENTER again to exit and save the adjustments.
- f) Use the MODE button at any point, to return to the previous sub-menu to make additional adjustments. "SAVE SETTINGS" stores changes in memory.

Time Delay Overview

MultEQ determines the default delay during initial Setup. However, there may be times when the delay needs to be tweaked or temporarily modified. Be advised, any changes made causes deviation from MultEQ's default specs and no longer conforms to its ideal sound stage. All channels have delays adjustable from 0 to 10ms in 0.1ms steps.

Time Delay

1. Press MODE twice to enter Custom Tuning mode.
2. With "PRESET 1" in the display, use the ▼ or ▲ buttons to choose the MIC position to modify.
 - a) PRESET 1 refers to the Primary Mic position. PRESET 2 refers to the Second mic position.
 - b) Upon making the Mic Position selection, use the ► button to move to the next selection mode. The next parameter to modify (Crossover, or Time Delay) is selected as described below.
 - * Use the ◀ button to return to the PRESET selection mode.
 - c) Use the ▼ or ▲ buttons to choose TIME DELAY.
 - d) Press the ► button to move to the Channel selection mode.
 - e) Use the ▼ or ▲ buttons to select a Channel to modify (FRONT LEFT 1/RIGHT 1, FRONT LEFT 2/RIGHT 2, REAR LEFT,RIGHT, SUBWOOFER). Use the ◀ button to return to the PRESET selection mode.
3. Time Correction
 - a) With the desired channel selected, press ENTER, to begin the adjustment.
 - b) Use the ▼ or ▲ buttons to change the delay (from 0 to 10ms) for each channel.
 - c) Upon completing the adjustment, press ENTER to exit back to the "TIME DELAY" sub-menu.
 - d) If all "TIME DELAY" adjustments have been completed, use the ◀ button to return to the PRESET selection mode. Press ENTER again to exit and save the adjustments. Selecting "SAVE SETTINGS" stores changes in memory.
 - e) Use the MODE button at any point, to return to the previous sub-menu. to make additional adjustments.

NOTES:

- Customization alters the MultEQ post-calibration settings. Doing this may or may not result in an improvement of the overall sound quality.
- If setup includes a 2-Way output, the FRONT 1 High-pass and FRONT 2 Low-pass cut-off frequencies should not be altered during customization. If these crossover points must be changed, the MultEQ calibration must also be rerun.

MOUNTING

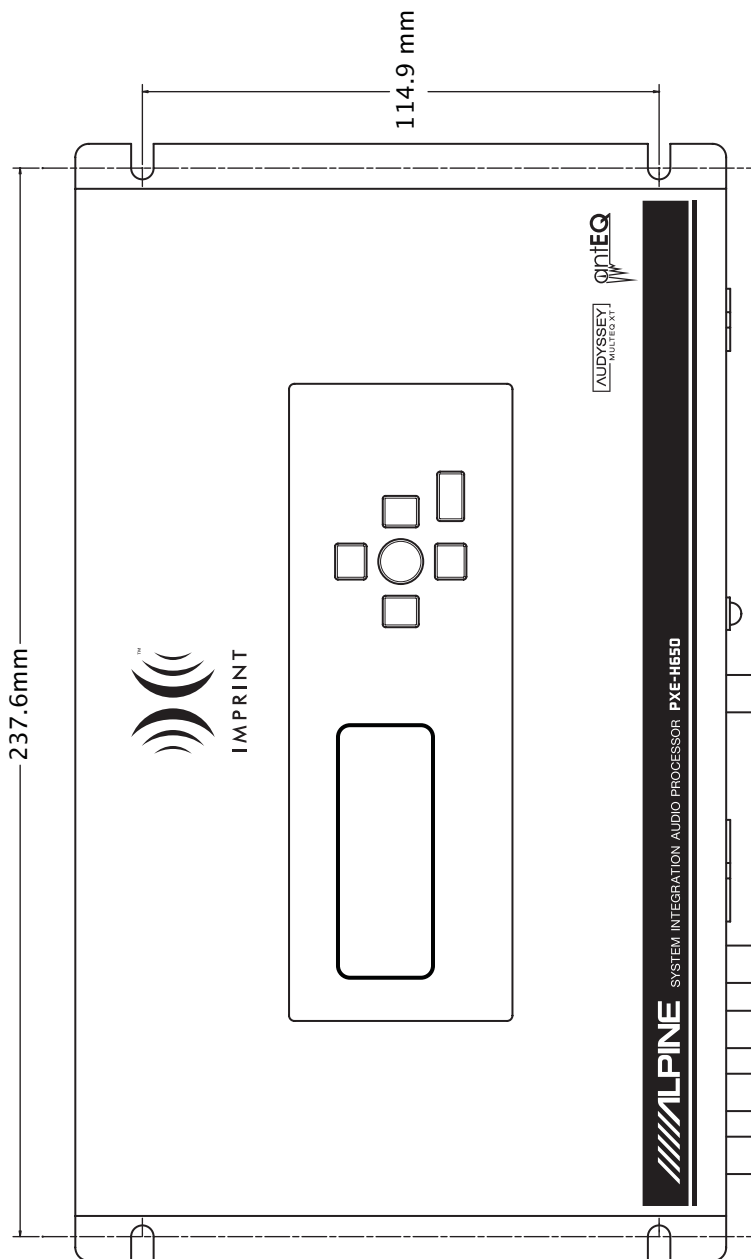

ADJUSTMENTS & RANGES

3 Band Parametric

- Q 0.5 to 2 (0.5 steps)
- Level -6 to +6 dB (1 dB steps)
- Bass Frequency..... Fc = 30, 40, 50, 60, 80, 100, 125, 150 Hz
- Mid Fc = 0.5, 0.75, 1.0, 1.5, 2.0, 3.0, 4.0, 5.0 kHz
- Treble..... Fc = 6, 7.5, 10, 12.5, 15, 17.5 kHz

Digital Crossovers 2-Way

High Pass (@ -12 dB/oct)

- F1.....200, 220, 250, 280, 315, 360, 400, 450, 500, 560, 630, 710, 800, 900, 1k
..... 1.2k, 1.4k, 1.6k, 1.8k, 2k, 2.2k, 2.5k, 2.8k, 3.2k, 3.6k, 4k, 4.5k, 5k Hz
- F2..... 50, 60, 70, 80, 90, 100, 110, 120, 130, 140, 150, 160, 170, 180, 190, 200 Hz
- R..... 50, 60, 70, 80, 90, 100, 110, 120, 130, 140, 150, 160, 170, 180, 190, 200 Hz

Low Pass (@ -12 dB/oct)

- F2.....200, 220, 250, 280, 315, 360, 400, 450, 500, 560, 630, 710, 800, 900, 1k
..... 1.2k, 1.4k, 1.6k, 1.8k, 2k, 2.2k, 2.5k, 2.8k, 3.2k, 3.6k, 4k, 4.5k, 5k Hz

..... **Normal (Full Range)**

High Pass (@ -12 dB/oct)

- F2..... 50, 60, 70, 80, 90, 100, 110, 120, 130, 140, 150, 160, 170, 180, 190, 200 Hz
- R..... 50, 60, 70, 80, 90, 100, 110, 120, 130, 140, 150, 160, 170, 180, 190, 200 Hz

Subwoofer (@ -12/-24 dB/oct)

- 50, 60, 70, 80, 90, 100, 110, 120, 130, 140, 150, 160, 170, 180, 190, 200 Hz

General

- User Memory2 Presets
- PC Control Interface..... USB
- Pre-amp Control..... Volume/Balance/Fader/Sub Level
- Source Select HU (Factory)/AUX
- Remote Turn-on Automatic Input Signal Sensing
- Turn-off Delay 5 minutes

SPECIFICATIONS

		SPECIFICATION	VALUE
MAIN UNIT	MAIN Input	Max Input Level	16 Vrms
	AUX Input	Max Input Level	1.5 Vrms (AUX PRIMARY OFF)
		Max Input Level	2.5 Vrms (AUX PRIMARY ON)
		Output Impedance	< 1kΩ
		Frequency Response	20 Hz to 20 kHz
		THD	< 0.2%
		SNR	82 dB
	GENERAL		Power Requirement
		Operating Current	< 700 mA
		Operating Temperature	+14°F to +140°F -10°C to +60°C)
		Dimensions	252mm x 38mm x 149mm
		Weight	1.0kg/35.3 oz

Accessories

RUE-4265 Remote Control.....	x 1
Power Supply Connector.....	x 1
Speaker Input Connector.....	x 1
Microphone.....	x 1
IR Remote Sensor.....	x 1
MultEQ LED.....	x 1
Batteries (AAA).....	x 2
Owner's Manual.....	x 1
Imprint Setup CD.....	x 1

NOTES:

Due to continuous product improvements, specifications and design are subject to change without notice.

TYPICAL OEM SYSTEM

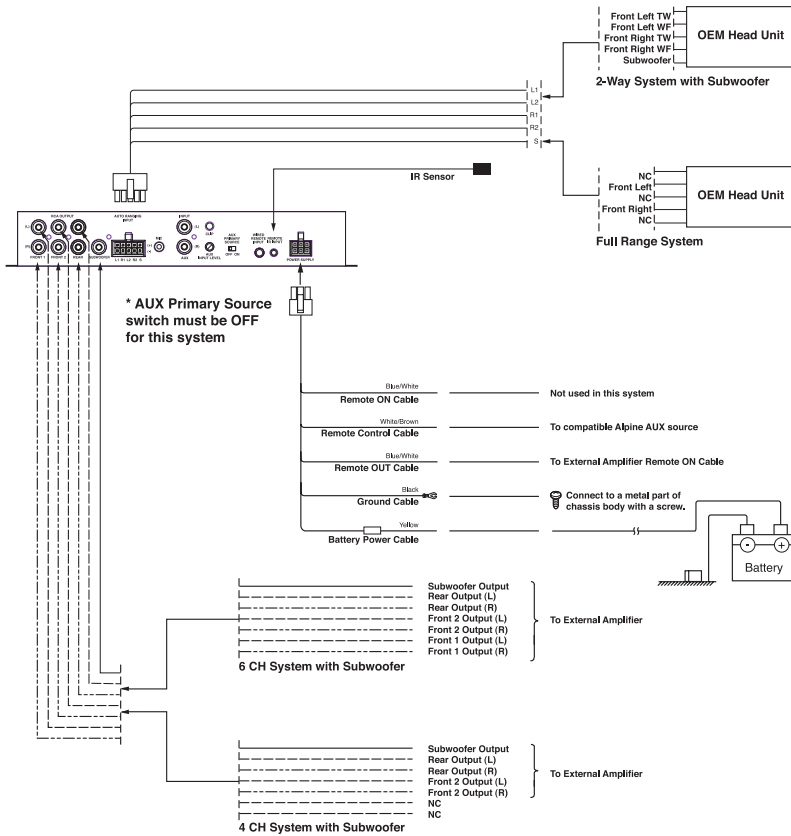

TYPICAL AFTERMARKET SYSTEM

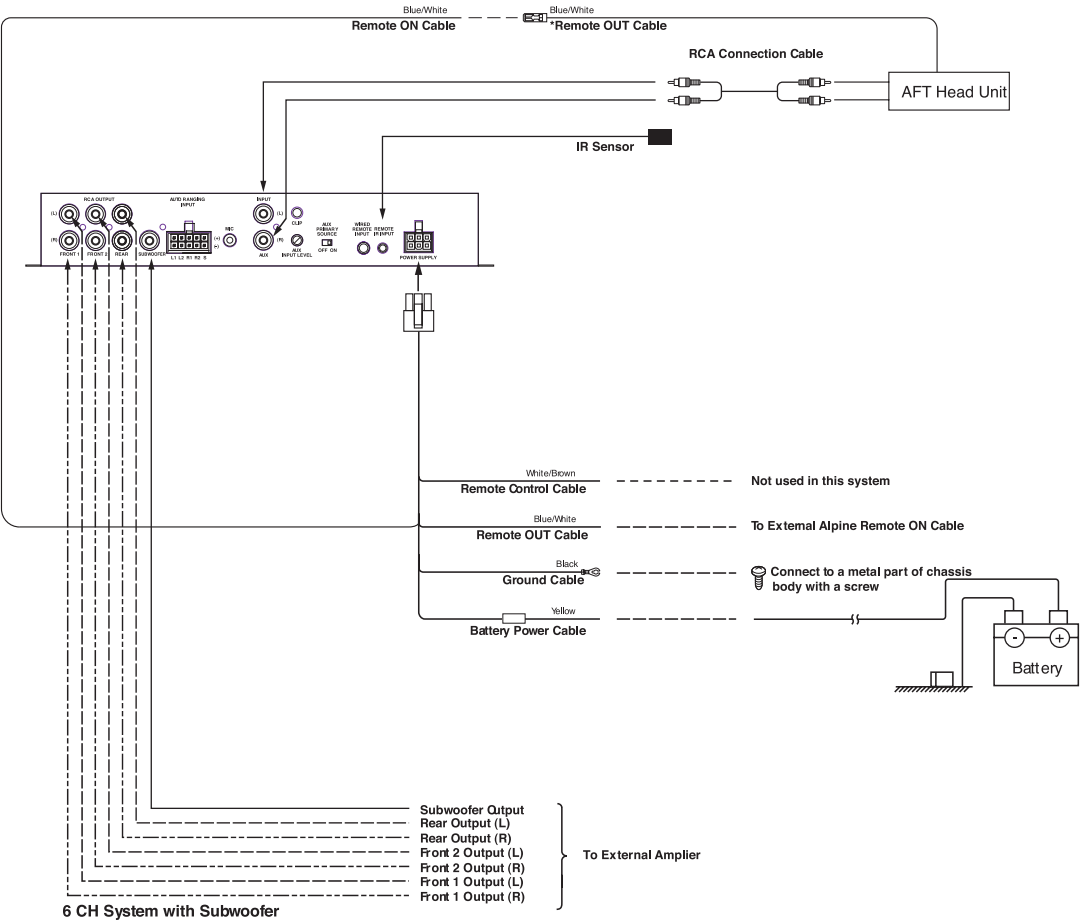

* AUX Primary Source switch must be ON for this system

LIMITED WARRANTY

LIMITED WARRANTY

ALPINE ELECTRONICS OF AMERICA, INC. AND ALPINE OF CANADA INC. ("Alpine"), are dedicated to quality craftsmanship and are pleased to offer this Warranty. We suggest that you read it thoroughly. Should you have any questions, please contact your Dealer or contact Alpine at one of the telephone numbers listed below.

●PRODUCTS COVERED:

This Warranty covers Car Audio, Navigation Products and Related Accessories ("the product"). Products purchased in the Canada are covered only in the Canada. Products purchased in the U.S.A. are covered only in the U.S.A.

●LENGTH OF WARRANTY:

This Warranty is in effect for one year from the date of the first consumer purchase.

●WHO IS COVERED:

This Warranty only covers the original purchaser of the product, who must reside in the United States, Puerto Rico or Canada.

●WHAT IS COVERED:

This Warranty covers defects in materials or workmanship (parts and labor) in the product.

●WHAT IS NOT COVERED:

This Warranty does not cover the following:

- 1 Damage occurring during shipment of the product to Alpine for repair (claims must be presented to the carrier).
- 2 Damage caused by accident or abuse, including burned voice coils caused by over-driving the speaker (amplifier level is turned up and driven into distortion or clipping).
Speaker mechanical failure (e.g. punctures, tears or rips).
Cracked or damaged LCD panels. Dropped or damaged hard drives.
- 3 Damage caused by negligence, misuse, improper operation or failure to follow instructions contained in the Owner's manual.
- 4 Damage caused by act of God, including without limitation, earthquake, fire, flood, storms or other acts of nature.
Any cost or expense related to the removal or reinstallation of the product.
- 5 Service performed by an unauthorized person, company or association.
- 6 Any product which has the serial number defaced, altered or removed.
- 7 Any product which has been adjusted, altered or modified without Alpine's consent.
- 8 Any product not distributed by Alpine within the United States, Puerto Rico or Canada.
- 9 Any product not purchased from an Authorized Alpine Dealer.

●HOW TO OBTAIN WARRANTY SERVICE:

1 You are responsible for delivery of the product to an Authorized Alpine Service Center or Alpine for repair and for payment of any initial shipping charges. Alpine will, at its option, repair or replace the product with a new or reconditioned product without charge. If the repairs are covered by the warranty, and if the product was shipped to an Authorized Alpine Service Center or Alpine, Alpine will pay the return shipping charges.

2 You should provide a detailed description of the problem(s) for which service is required.

3 You must supply proof of your purchase of the product.

4 You must package the product securely to avoid damage during shipment. To prevent lost packages it is recommended to use a carrier that provides a tracking service.

●HOW WE LIMIT IMPLIED WARRANTIES:

ANY IMPLIED WARRANTIES INCLUDING FITNESS FOR USE AND MERCHANTABILITY ARE LIMITED IN DURATION TO THE PERIOD OF THE EXPRESS WARRANTY SET FORTH ABOVE AND NO PERSON IS AUTHORIZED TO ASSUME FOR ALPINE ANY OTHER LIABILITY IN CONNECTION WITH THE SALE OF THE PRODUCT.

●HOW WE EXCLUDE CERTAIN DAMAGES:

ALPINE EXPRESSLY DISCLAIMS LIABILITY FOR INCIDENTAL AND CONSEQUENTIAL DAMAGES CAUSED BY THE PRODUCT. THE TERM "INCIDENTAL DAMAGES" REFERS TO EXPENSES OF TRANSPORTING THE PRODUCT TO THE ALPINE SERVICE CENTER, LOSS OF THE ORIGINAL PURCHASER'S TIME, LOSS OF THE USE OF THE PRODUCT, BUS FARES, CAR RENTALS OR OTHERS COSTS RELATING TO THE CARE AND CUSTODY OF THE PRODUCT. THE TERM "CONSEQUENTIAL DAMAGES" REFERS TO THE COST OF REPAIRING OR REPLACING OTHER PROPERTY WHICH IS DAMAGED WHEN THIS PRODUCT DOES NOT WORK PROPERLY.

THE REMEDIES PROVIDED UNDER THIS WARRANTY ARE EXCLUSIVE AND IN LIEU OF ALL OTHERS.

●HOW STATE/PROVINCIAL LAW RELATES TO THE WARRANTY:

This Warranty gives you specific legal rights, and you may also have other rights which vary from state to state and province to province. In addition, some states/provinces do not allow limitations on how long an implied warranty lasts, and some do not allow the exclusion or limitation of incidental or consequential damages. Accordingly, limitations as to these matters contained herein may not apply to you.

●IN CANADA ONLY:

This Warranty is not valid unless your Alpine car audio product has been installed in your vehicle by an Authorized Installation Center, and this warranty stamped upon installation by the installation center.

●HOW TO CONTACT CUSTOMER SERVICE:

Should the product require service, please call the following number for your nearest Authorized Alpine Service Center.

CAR AUDIO 1-800-ALPINE-1 (1-800-257-4631)

Or visit our website at; <http://www.alpine-usa.com>

ALPINE ELECTRONICS OF AMERICA, INC.,
19145 Gramercy Place, Torrance, California 90501, U.S.A.

ALPINE ELECTRONICS OF CANADA, INC.,
777 Supertest Road, Toronto, Ontario M3J 2M9, Canada Phone 1-416-736-6211
Do not send products to these addresses.

Call the toll free telephone number or visit the website to locate a service center.

© 2006 Alpine Electronics of America, Inc. All Rights Reserved.





ALPINE ELECTRONICS, INC.

Tokyo office; 1-1-8 Nishi Gotanda,
Shinagawa-ku, Tokyo 141-8501, Japan
Tel.: (03) 3494-1101

ALPINE ELECTRONICS OF AMERICA, INC.

19145 Gramercy Place, Torrance,
California 90501, U.S.A.
Tel.: 1-800-ALPINE1 (1-800-257-4631)
1-888-NAV-HELP (1-888-628-4357)

ALPINE ELECTRONICS OF CANADA, INC.

Suite 203, 7300 Warden Ave. Markham, Ontario
L3R 9Z6, Canada
Tel.: 1-800-ALPINE1 (1-800-257-4631)

ALPINE ELECTRONICS OF AUSTRALIA PTY. LTD.

6-8 Fiveways Boulevard Keysborough Victoria 3173,
Australia
Tel.: (03) 9769-0000

ALPINE ELECTRONICS GmbH

Kreuzerkamp 7-11 40878 Ratingen, Germany
Tel.: 02102-45 50

ALPINE ITALIA S.p.A.

Via C.Colombo 8, 20090 Trezzano
Sul Naviglio MI, Italy
Tel.: 02-48 47 81

ALPINE ELECTRONICS FRANCE S.A.R.L.

98, Rue De La Belle Etoile, Z.I. Paris Nord II B.P.50016
F-95945, Roissy, Charles De Gaulle Cedex, France
Tel.: 01-48 63 89 89

ALPINE ELECTRONICS OF U.K., LTD.

13 Tanners Drive, Blakelands,
Milton keynes MK14 5BU, U.K.
Tel.: 01908-61 15 56

ALPINE ELECTRONICS DE ESPAÑA, S.A.

Portal De Gamarra 36, Pabollón 32
01013 Vitoria(Alava)-Apdo. 133, Spain
Tel.: 34-45-283588